



Classic Tulip Half Sconce

Product Specifications



TCP's LED Classic Tulip Half Sconce provides long-lasting illumination for both residential and commercial applications. This "bulb-in-a-box" solution comes prepackaged with an LED bulb for ease of installation and a guarantee of high CRI, flicker-free LED performance.

Reasons to Choose the Classic Tulip Half Sconce from TCP

- LED bulb included (A19, E26)
- Three color temperatures available: 2700K, 3000K or 4100K
- High 90 CRI value provides excellent color rendering and consistency
- Dimmable
- Brushed nickel finish
- Tulip frosted glass shade
- Five-year limited warranty

Ideal Applications

- Residential
- Hospitality
- New construction
- Remodeling

Specifications

Input Line Voltage	120V	Color Temperature	2700K, 3000K, 4100K
Input Line Frequency.....	60Hz	Lamp Life (hours).....	25,000
Wattage (W).....	6W	Minimum Starting Temperature	-22°C (-8°F)
Lumens (L).....	475L	Maximum Operating Temperature.....	45°C (113°F)
LPW	79	Certification	cETLus
CRI.....	90	Warranty.....	5-year limited

Dimensions

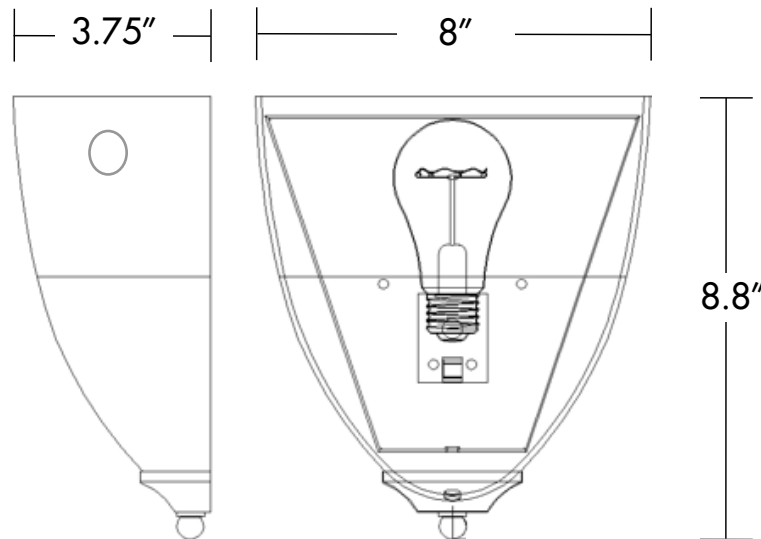

Ordering Information

ITEM #	DESCRIPTION	COLOR	TITLE 20	JA8
CLHSC1TLBND27K	Classic Half Sconce Tulip 1-Lamp BN Dim 27K	2700K	Y	Y
CLHSC1TLBND30K	Classic Half Sconce Tulip 1-Lamp BN Dim 30K	3000K	Y	Y
CLHSC1TLBND41K	Classic Half Sconce Tulip 1-Lamp BN Dim 41K	4100K	Y	N

TECHNOLOGY CAST IN A BEAUTIFUL LIGHT

For over 20 years, TCP has been designing, developing and delivering energy-efficient lighting into the market. Thanks to our cutting-edge technology and manufacturing expertise, we have shipped billions of high quality lighting products. With TCP, you can count on a lighting product that is designed to meet the needs of the market - that transforms your surroundings and envelopes you in warmth - lighting that generates beauty with every flip of the switch.

Sales:

Date:

Model:

Project:

Rep:

Catalog Number:

Type:

Notes:



For more information on the quality and care TCP can deliver, call us at **800.324.1496** or visit tcp.com

325 Campus Dr. | Aurora, Ohio 44202 | P: 800.324.1496 | F: 877.487.0516