



<b>Instant Start Electronic Ballast</b>	120 or 277 Voltage
---	--------------------

**Application and Performance:**

- Energy saving high efficiency instant start electronic ballast (> 90%)
- Multi-voltage technology handles voltage from 120 to 277v
- Anti-Striation Control for better light quality, with no striations
- Active Power Factor Correction - Ballast regulates the output to each lamp with individual lamp inverter modules

**General Characteristics:**

Application	3 or 2 F32T8 120 to 277v 1.18BF
Ballast Type	Electronic – High Efficiency Multivolt Instant Start
Starting Method	Instant Start
Lamp Wiring	Parallel
Line Voltage Regulation (+/-)	10%
Ambient Temp (Max)	105°F / 41°C
Case Temp (Max)	167°F / 75°C
Ballast Factor	Low (1.18)
Sound Rating	A
Supply Current Frequency	50 Hz / 60 Hz



Catalog Number	
Notes	Type

**Dimensions:**

**CASE DIMENSIONS**

Length (L)	9.5 in
Width (W)	1.3 in
Height (H)	1.2 in

**LEAD LENGTHS**

White/Black	25 in
Red/Blue	31 in
Weight	1.1 lbs.
Exit Type	Side
Remote Mounting	
Distance to lamp	18 ft.
Remote Mounting	
Wire Gauge	18 AWG
Case Quantity	10
UPC	762148136200

For the most up-to-date specs, please visit [www.tcpi.com](http://www.tcpi.com)



Lamp Type	Line Volt.	Num. of Lamps	Rated Lamp Watts	Min. Start Temp. (°F/°C)	Input Current (Amps)	Input Power (Watts)	MAX. THD%	Power Factor	Ballast Factor	MAX. Lamp Current Crest Factor	B.E.F.
<b>F32T8</b>	120	3	32	0/-18	0.93	109	10	0.98	1.18	1.70	1.08
		2	32	0/-18	0.70	82	10	0.98	1.27	1.70	1.55
	277	3	32	0/-18	0.39	107	15	0.98	1.18	1.70	1.10
		2	32	0/-18	0.30	81	15	0.98	1.27	1.70	1.57
<b>F28T8</b>	120	3	28	0/-18	0.82	96	10	0.98	1.18	1.60	1.23
		2	28	0/-18	0.61	72	10	0.98	1.27	1.60	1.76
	277	3	28	0/-18	0.35	94	15	0.98	1.18	1.60	1.26
		2	28	0/-18	0.27	72	15	0.98	1.27	1.60	1.76
<b>F25T8</b>	120	3	25	0/-18	0.75	88	10	0.98	1.18	1.60	1.34
		2	25	0/-18	0.55	65	10	0.98	1.30	1.60	2.00
	277	3	25	0/-18	0.32	87	15	0.98	1.18	1.60	1.36
		2	25	0/-18	0.24	65	15	0.98	1.30	1.60	2.00
<b>F17T8</b>	120	3	17	0/-18	0.51	60	10	0.98	1.19	1.60	1.98
		2	17	0/-18	0.39	46	10	0.98	1.32	1.60	2.85
	277	3	17	0/-18	0.23	60	15	0.96	1.19	1.60	1.99
		2	17	0/-18	0.18	46	18	0.94	1.32	1.60	2.86

Note: the above data is tested at 60Hz.

Application and Performance Specification Information Subject to Change without Notification.

Fully meets UL&CUL safety standards.

### Performance:

- Meets ANSI Standard C82.11-1993
- Meets ANSI Standard C62.41-1991
- Meets FCC 18 Non CONSUMER Limits
- NEMA Premium

### Safety:

- No PCB's
- UL Listed (Class P, Type 1 Outdoor)
- OCV 600V

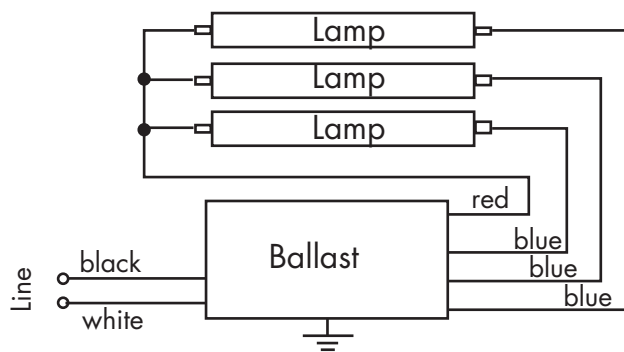

For the most up-to-date specs, please visit [www.tcpi.com](http://www.tcpi.com)

Note: For two lamps application, cap any blue/red lead. Insulate to 600 volts.