

TCP's New Fixture-Mounted Infrared High-Bay Occupancy Sensor

PROJECT _____

LOCATION/TYPE _____

Features & Benefits

- Quick and easy installation: provides a self-contained, line-voltage occupancy sensor that connects to individual fixtures using standard 1/2" knockouts
- Snap-in install feature: threaded nipple is also provided with an integral catch for double-D 1/2" knockouts
- Convenient LED status indicator: green LED provides confirmation that the occupancy sensor is functioning properly
- Timer settings: unit is shipped set to 30 second default
- Accommodates high-bay 8–40 ft. mounting heights
- Masking kit provided with each unit to "block" area where sensing detection is not desired
- Zero-crossing circuitry for greater reliability: built-in relay uses zero-crossing circuitry to provide reliable, long-life operation

Description

The TCPOS is a self-contained occupancy sensor and relay that turns individual light fixtures ON/OFF based on occupancy in a detection zone. It uses passive infrared (PIR) technology to sense line-of-sight motion by comparing the infrared energy from an object-in-motion with the background space. The sensor includes a microprocessor-based digital architecture that minimizes false ON triggering due to background environmental conditions such as air movement.

Lenses

The TCPOS comes with three interchangeable lenses for high-bay, low-bay, and aisle way patterns. The 360° high-bay PIR lens provides a 2:1 spacing to mounting height coverage under 25 ft. mounting and a 1.5:1 for heights up to 40 ft. mounting. The 360° low-bay lens provides 2:1 spacing to mounting height coverage for 8 ft. to 20 ft. mounting. The aisle lens is designed to provide detection of 60 ft. long by 20 ft. wide for heights up to 40 ft. mounting. The TCPOS is also available in a model for cold storage applications with temperatures as low as -40° F. Each lens is easily interchangeable by rotating the lens 90° to pop in and out.

Application

TCP's fixture-mounted infrared high-bay occupancy sensor is designed specifically for pre-wiring or retrofitting in high-mounting areas such as warehouses, manufacturing and other high-ceiling applications. The automated line-of-sight, occupancy sensor-controlled ON/OFF switching of lighting provides energy savings and safety benefits.



High Bay 360° Lens | White

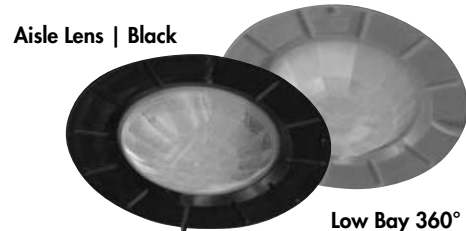

Aisle Lens | Black

Low Bay 360° Lens | Blue

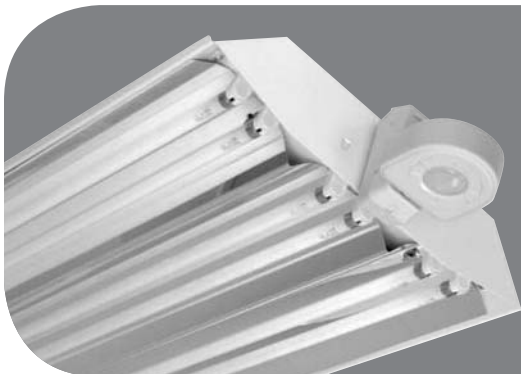

Ordering Information

Item#	Description
TCPOS	Fixture-Mounted PIR High-Bay Sensor with 3 Interchangeable Lenses, White
TCPOSC	Fixture-Mounted PIR High-Bay Sensor with 3 Interchangeable Lenses for Cold Storage, White
TCPOS4	Fixture-Mounted PIR High-Bay Sensor with 3 Interchangeable Lenses, 480V, No Neutral, White
TCPOS4C	Fixture-Mounted PIR High-Bay Sensor with 3 Interchangeable Lenses for Cold Storage, 480V, No Neutral, White

Photometrics

High Bay 360° Lens

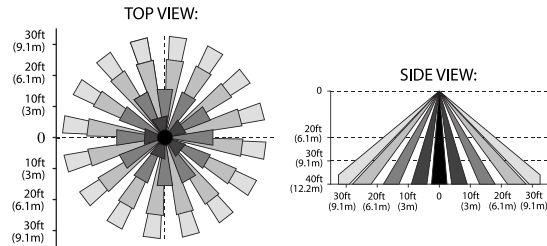

Low Bay 360° Lens

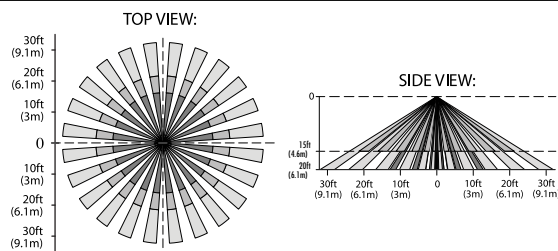

Aisle Lens

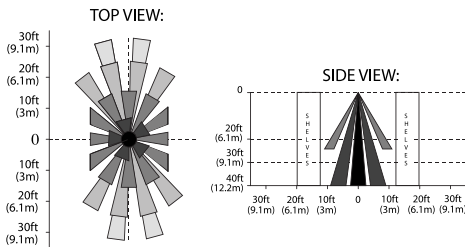

Installation

The TCPOS installs directly onto an industrial fluorescent fixture through the supplied snap-in mounting bracket. The snap-in mounting bracket is used to position the TCPOS below the fixture body to improve the sensor's field-of-view. The TCPOS is a two piece plastic offset that installs into the fixture's 1/2" knockout. Wiring is routed through the TCPOS to the fixture body.

Sheet Metal* Punch Dimensions for Snap-In Mounting Bracket Installation

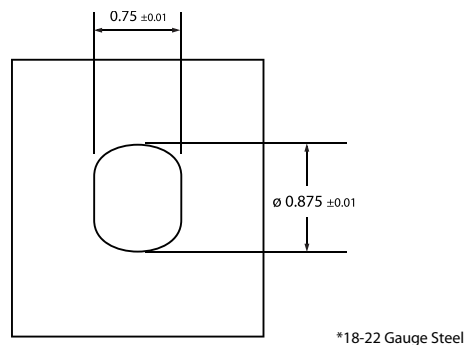

Specifications

ELECTRICAL

Input Voltage: 120/277/347 VAC

Input Voltage: 480 VAC

Operational Frequency: 50/60Hz

Wire Designation: Line-Black, Load-Red, Neutral-White

Load Rating: Fluorescent Ballasts – 800VA @ 120 VAC, 1200VA @ 277 VAC, 1500VA @ 347 VAC, 2000VA @ 480 VAC;

Motor – 1/4 HP Load @ 120V

ENVIRONMENTAL

Operating Temperature Range:

TCPOS: 14°F to 160° TCPOSC: -40°F to +40°F

Storage Temperature Range: -14°F to 160°F

Relative Humidity: 20% to 90% non-condensing

PHYSICAL

TCPOS/TCPOSC

Size: 3.50" H x 3.50" W x 1.25" D

Color: White

Construction: Housing is high-impact, injection molded plastic.

Color coded wire leads 42" long.

Snap-In Mounting Bracket

Size: 4.50" H x 2.00" W x 2.00" D Color: White

Construction: Housing is high-impact, injection molded plastic.

AGENCY STANDARDS & COMPLIANCE

TCPOS/TCPOSC

- UL and cUL Listed

- Backed by Limited Five-Year Warranty

Installation Wiring Diagram for TCPOS

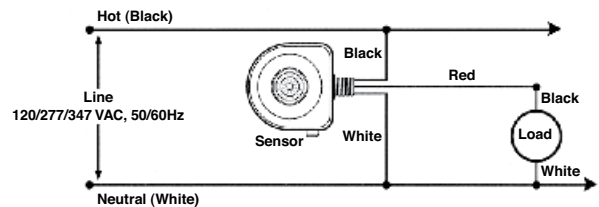

Installation Wiring Diagram for 480V TCPOS

