



51018 Series Outdoor Pagoda Fixture Specifications

18 Watt SpringLamp®

- GX base, NPF Compact Fluorescent, 10,000 Hours lamp life, 50,000 Hours ballast life

Item #	Description	Incandescent wattage comparison	Initial Lumens	Input Line Current	Replacement Lamp	M.O.L.
51018BPC ★	18W Outdoor Wall Mounted Pagoda Fixture Black w/Photo Cell	90	1410	.29A	33018	9"
51018WPC ★	18W Outdoor Wall Mounted Pagoda Fixture White w/Photo Cell	90	1410	.29A	33018	9"

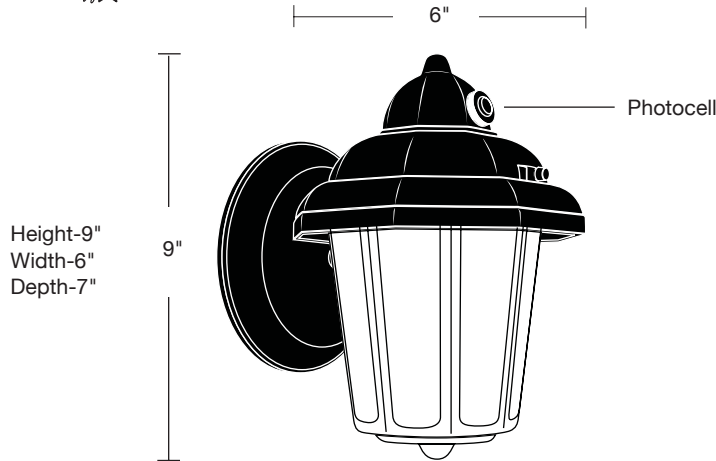
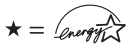

2 Piece SpringLamp



Specifications (at full brightness)

End of Life Protection-----	Yes
Ballast Type -----	Electronic
Starting Method -----	Modified Rapid Start
Input Line Voltage -----	120VAC
Input Line Frequency -----	50/60HZ
Lamp Life (rated) -----	10,000 Hours
Ballast Life (rated) -----	50,000 Hours
Color Temperature -----	2700°K
Color Rendering Index -----	84
Minimum Starting Temperature -----	-20 ° F
Maximum Operating Temperature -----	160 ° F
U.L. / C.U.L. Listed -----	Yes
FCC Compliance -----	Part 18, Subpart C
Lamp Operating Frequency -----	45 KHZ
Lamp Current Crest Factor -----	< 1.60
Maximum Open Circuit Voltage -----	600V
Power Factor -----	>.50
Total Harmonic Distortion -----	< 150%
Dimming Range -----	N/A

Applications:

- Use outdoors, mounts to any wall
- Perfect for: porches, doorways, and garages

Features and Benefits

- UL approved for wet locations
- Fixtures automatically include Photocell for dusk to dawn applications
- Long life, 10,000 hour average rated lamp life
50,000 hour average rated ballast life
- Lasts 7 years, based on 3 hours use per day
- Lasts 10 times longer than similar incandescent
- Quick run-up time
- Instant start, flicker free
- Replaceable Ballast, snap in / no rewiring
- World class phosphor insures high lumen output and excellent lumen maintenance



ISO 9002
CERTIFIED

2 YEAR
WARRANTY